



PC-TFT-25XS

Interface Board

Features

- Used for TFT-LCD display: 2.5" AND-TFT-25XS-LED
- Compatible with NTSC or PAL system
- High Resolution: 112,320 dots
- Optimum Viewing Direction: 6 o'clock
- Up/Down and Left/Right Image Reversion

The PC-TFT-25XS is designed to work with the AND-TFT-25XS-LED color TFT display which is suitable for camcorders, digital camera applications and other electronic products which require high quality flat panel displays.

Mechanical Characteristics

Item	Specification	Unit
Screen Size	2.45 (diagonal)	inch
Surface Treatment	Anti-Glare	-
Display Format	160 x 234	dot
Active Area	49.68 (W) x 37.44 (H)	mm
Dot Pitch	0.1035 (W) x 0.160 (H)	mm
Pixel Configuration	Stripe	-
Outline Dimension	60.6 (W) x 48.4 (H) x 3.45 (D)	mm
Weight	20 ± 3	g
Contrast Ratio	350:1	
View Angle	(V) +15 °C / -35°C (H) ± 50°C	
Color	Full Color	
Brightness	250	cd/m2

Please refer to data sheet for AND-TFT-25PXS-LED for more details on panel information.

Absolute Maximum Rating

Item	Symbol	Specifications		Unit	Remarks
		Min.	Max.		
Input Voltage	V _{in}	+8	+16	V	
Input Voltage	V _{in}	+4	+6	V	
Video Input Signal	Video in	0.5	2.0	V _{p-p}	Note 1
Digital Input Signal	TTL	+0.3	+5.3	V	
Operating Temperature		-10	60	°C	
Relative Humidity		5	90	%RH	
Storage Temperature		-25	80	°C	
Relative Humidity		0	90	%RH	
Supply Voltage	V _L	-	13.2	V	I _L =20mA
Supply Current	I _L	-	20	mA	

Note 1: @ 75 Ω

Product specifications contained herein may be changed without prior notice.

It is therefore advisable to contact Purdy Electronics before proceeding with the design of equipment incorporating this product.



Electrical Characteristics - Operating Conditions

Item	Symbol	I/O	Specifications			Unit	Remarks
			Min.	Typ.	Max.		
Input Voltage	V _{in}	I	+10	+12	+14	V	
Total Current	I _{in}	I		153		mA	
Power Consumption		I		1.84		W	@+12V
Input Voltage	V _{in}	I	+4	+5	+6	V	
Total Current	I _{in}	I		300		mA	
Power Consumption		I		1.5		W	@+5V
Video Input Signal	Video in	I		-1.0		Vp-p	@ 75 Ω
Output Voltage	+5V	O	-	+5V		V	
Brightness Adjust	Bright	I	+1.13	+1.3	+1.43	V	
Contrast Adjust	Contrast	I	+2.10	+2.57	+2.98	V	
Color Adjust	Color	I	+2.26	+2.72	+3.59	V	
Tint Adjust	Tint (NTSC only)	I	+1.5	+3.09	+4.6	V	
Viedo Auto Detect	NTSC/PAL	O	-	TTL		V	

Current Consumption (GND = AV_{SS} = 0V)

Item	White Window	Red	Green	Blue	Remark
S/N: 001 x	0.307	0.558	0.340	0.161	
y	0.326	0.349	0.541	0.128	
L	300 (cd/m ²)	-	-	-	± 15%
TC	8650(°K)	-	-	-	

Note 1. Luminance: BM-7 FAST (TOPCON)

Note 2. Pattern Generator: FLUKE PM54200

Note 3. Measurement Distance: 500mm ± 500mm

Note 4. TOPCON BM-7 Luminance Meter 2° field of view is used in the testing (After 10 min ~ 20 min Operation)

LED Driver Data: Ta - 25°C @+5V

Item	Symbol	Specifications		Unit	Remark
		Min.	Typ.		
Supply voltage of LED backlight	V _L	-	13.8	V	I _L = 23.3 mA
Supply current of LED backlight	I _L	-	23.3	mA	



Terminal Pin Assignment

Pin No.	Symbol	I/O	Description
1	STH	I/O	Start pulse for source driver
2	AV _{SS}	I	Analog GND for source driver
3	AV _{DD}	I	Analog power input for source driver
4	V _B	I	Video Input B
5	V _G	I	Video Input G
6	V _R	I	Video Input R
7	V _{SS}	I	Digital GND
8	V _{DD}	I	Digital power input
9	CPH1	I	Sampling and shift clock for source driver
10	CPH2	I	Sampling and shift clock for source driver
11	CPH3	I	Sampling and shift clock for source driver
12	STH2	I/O	Start pulse for source driver
13	Q2H	I	Video input rotation control
14	INH	I	Output enable for source driver
15	R/L	I	Left/Right Control for source driver
16	V _{COM}	I	Common electrode voltage
17	XOE	I	Output enable for gate driver
18	CPV	I	Clock input for gate driver
19	U/D	I	Up/Down Control for gate driver
20	DIO2	I/O	Vertical start pulse
21	DIO1	I/O	Vertical start pulse
22	V _{GL}	I	Gate off voltage (alternative every 1-H)
23	V _{EE}	I	Gate driver negative voltage
24	V _{SS}	I	GND
25	V _{CC}	I	Logic power for gate driver
26	V _{GH}	I	Gate on voltage
27	NC	–	No connection
28	NC	–	No connection
29	GLD		Supply current for LED
30	VLED		Supply voltage for LED

J301: Pin Assignment of Signal Input (Pitch 1.25 mm 15P, Side Entry Type)

Pin No.	Symbol	I/O	Description	Remarks
1	Vin	I	+12 V Voltage Power supply	
2	GND	-	Power Ground	
3	GND	-	Power Ground	
4	GND	-	Signal Ground	
5	Video-IN	I	Video input (1Vp-p/75 Ω)	
6	+5V	O	Voltage DC Output	Note 1
7	Bright	I	Brightness control	
8	Contrast	I	Contrast control	
9	Color	I	Color control	
10	Tint	I	Tint control	Note 2
11	NTSC/PAL	O	Systemm Auto detect output	Note 3
12	LRC	I	Screen Left / Right reverse	Note 4
13	UDC	I	Screen Up / Down reverse	Note 4
14	Dimmer	I	Backlight brightness control	
15	Enable	I	Backlight On/Off	Note 5

Note 1: The +5V power supply external control circuit. (Max. output is 10mA)

Note 2: The TINT is only operating in NTSC system.

Note 3: The output High level for NTSC mode and Low level for PAL mode.

Note 4: Default +5V or floating is normal scanning and 0V is for reversed scanning.

Note 5: The floating or 0V is backlight on and 5V is backlight off.

Block Diagram

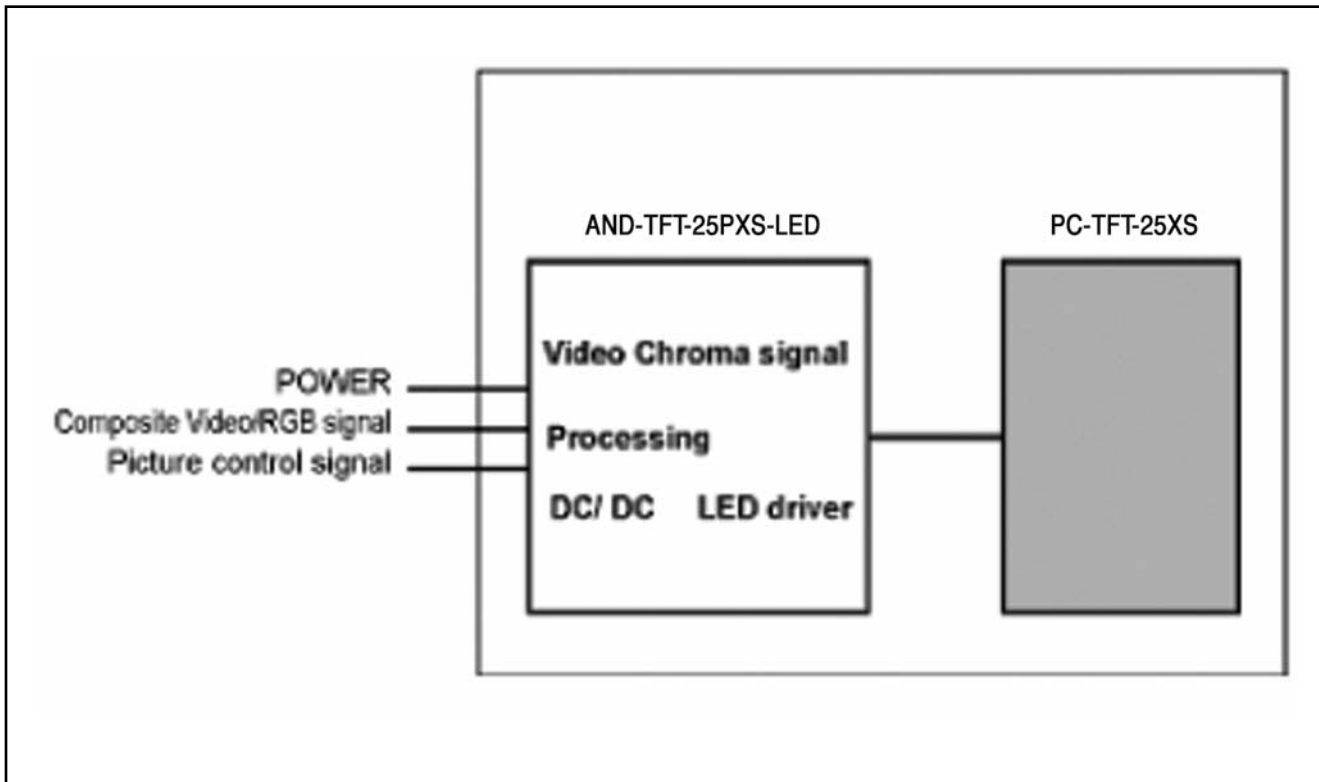

Application Circuit

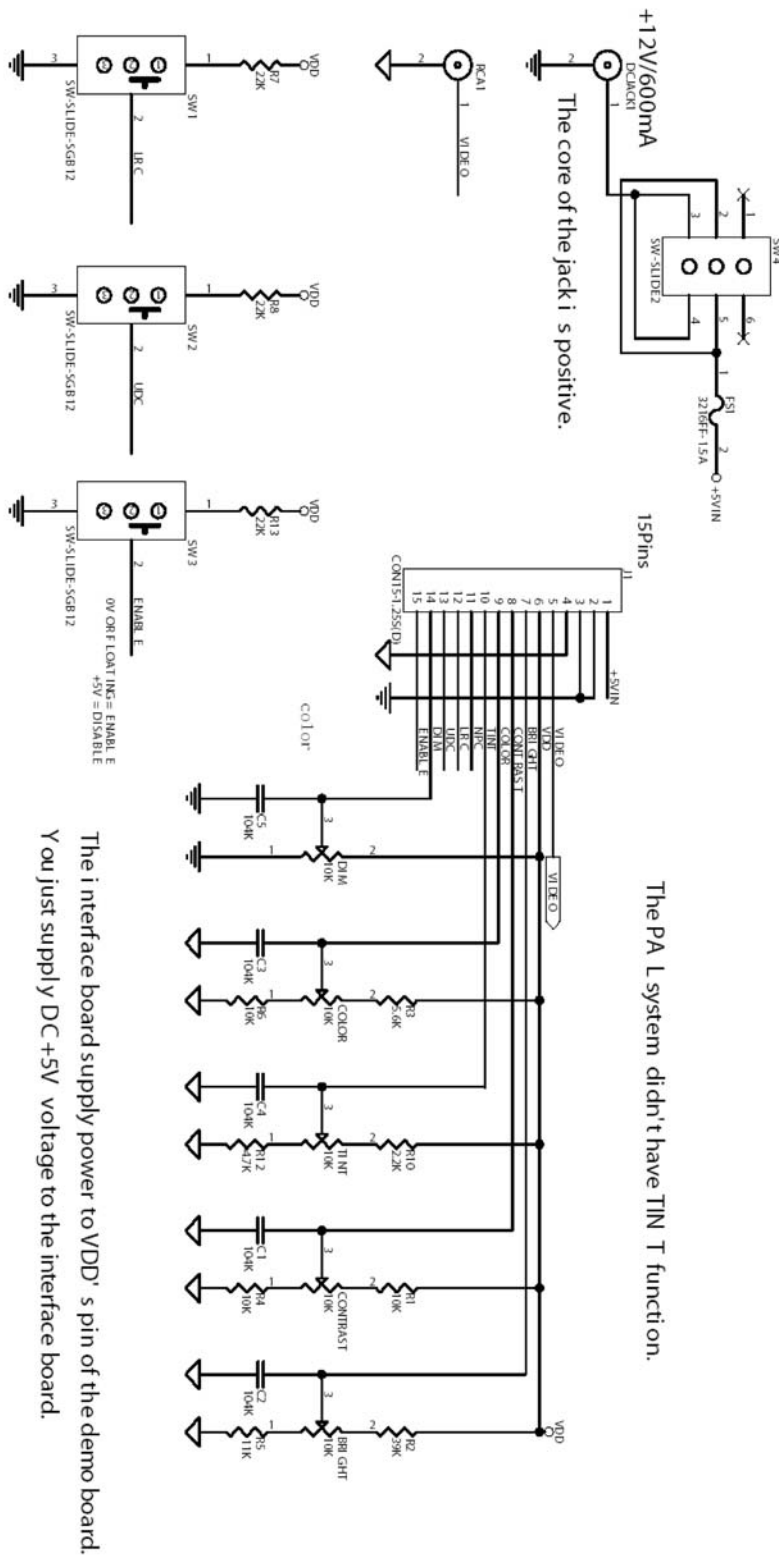

The interface board supply power to VDD's pin of the demo board. You just supply DC +5V voltage to the interface board.